

## Double-Ended Beam Load Cell

### FEATURES

- Capacities: 25k to 125k lbs
- Environmental protection: IP67 (DIN 40.050)
- Material: Nickel-plated steel
- Certified to NTEP class III L, 10000 divisions
- **Optional**
  - FM approved for use in potentially explosive atmosphere



### APPLICATIONS

- Weighbridges
- Silos, tanks and hoppers

### DESCRIPTION

The 5303 is a link loaded mid to high capacity, nickel-plated alloy steel double-ended shear beam type load cell.

This product is designed for use in certified truck and rail scales and is available in capacities from 25k to 125k lbs.

This load cell is rated intrinsically safe by the FM system, making it suitable for use in potentially explosive atmospheres.

This load cell is certified for trade applications by American NTEP standards.

### OUTLINE DIMENSIONS in inches

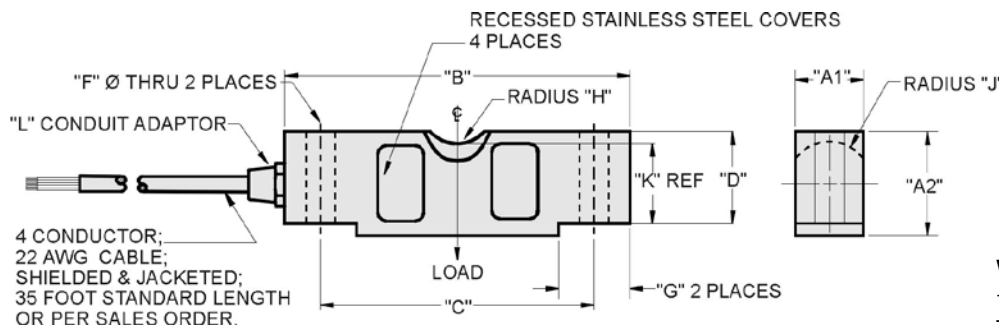

Wiring	
+Excitation	Red
-Excitation	Black
+Output	Green
-Output	White

CAPACITY	A <sub>1</sub>	A <sub>2</sub>	B	C	D	F	G	H	J	K	L
25k	1.69	1.94	7.75	6.50	1.70	0.68	1.38	0.75	0.90	1.63	1/4 - 18 NPT
40k	1.94	2.44	10.25	8.50	2.10	0.81	1.93	1.00	1.12	2.00	1/4 - 18 NPT
50k-75k	2.44	2.94	10.25	8.50	2.65	1.06	1.93	1.00	1.37	2.54	1/2 - 14 NPT
100k-125k	2.90	3.86	15.25	12.75	3.43	1.62	3.13	1.50	1.80	3.30	1/2 - 14 NPT

Capacities are in pounds

### Double-Ended Beam Load Cell

SPECIFICATIONS			
PARAMETER	VALUE		UNIT
Standard capacities (E <sub>max</sub> )	25k, 40k, 50k, 60k, 75k, 100k, 125k		lbs
Accuracy class according to NTEP	NTEP IIIIL	Non-Approved	
Maximum no. of verification intervals (n/c)	10000d		
Rated output (=S)	3.0		mV/V
Rated output tolerance	0.0075		±% mV/V
Zero balance	1.0		±% FSO
Combined error	0.0200	0.0500	±% FSO
Temperature effect on min minimum dead load output	0.0010	0.0250	±% FSO/5°C (1°F)
Temperature effect on sensitivity	0.0008	0.0250	±% FSO/5°C (1°F)
Compensated temperature range	-10 to +40 (+14 to 104)		°C (°F)
Operating temperature range	-18 to +65 (0 to +150)		°C (°F)
Safe load limit	150		% E <sub>max</sub>
Ultimate load	300		% E <sub>max</sub>
Safe side load limit	100		% E <sub>max</sub>
Excitation voltage recommended	10		V
Excitation voltage maximum	15		V
Input resistance	700±14		Ω
Output resistance	703±4		Ω
Insulation resistance	≥1000		MΩ
Environmental protection	IP67		
Element material	Nickel-plated steel		ASTM

#### Mounting:

Correct mounting of the load cells is essential to ensure optimum accuracy and performance. Further information is available upon request.

FSO—Full Scale Output

All specifications subject to change without notice.



## Disclaimer

ALL PRODUCTS, PRODUCT SPECIFICATIONS AND DATA ARE SUBJECT TO CHANGE WITHOUT NOTICE.

Vishay Precision Group, Inc., its affiliates, agents, and employees, and all persons acting on its or their behalf (collectively, "VPG"), disclaim any and all liability for any errors, inaccuracies or incompleteness contained herein or in any other disclosure relating to any product.

The product specifications do not expand or otherwise modify VPG's terms and conditions of purchase, including but not limited to, the warranty expressed therein.

VPG makes no warranty, representation or guarantee other than as set forth in the terms and conditions of purchase. **To the maximum extent permitted by applicable law, VPG disclaims (i) any and all liability arising out of the application or use of any product, (ii) any and all liability, including without limitation special, consequential or incidental damages, and (iii) any and all implied warranties, including warranties of fitness for particular purpose, non-infringement and merchantability.**

Information provided in datasheets and/or specifications may vary from actual results in different applications and performance may vary over time. Statements regarding the suitability of products for certain types of applications are based on VPG's knowledge of typical requirements that are often placed on VPG products. It is the customer's responsibility to validate that a particular product with the properties described in the product specification is suitable for use in a particular application. You should ensure you have the current version of the relevant information by contacting VPG prior to performing installation or use of the product, such as on our website at [vpgsensors.com](http://vpgsensors.com).

No license, express, implied, or otherwise, to any intellectual property rights is granted by this document, or by any conduct of VPG.

The products shown herein are not designed for use in life-saving or life-sustaining applications unless otherwise expressly indicated. Customers using or selling VPG products not expressly indicated for use in such applications do so entirely at their own risk and agree to fully indemnify VPG for any damages arising or resulting from such use or sale. Please contact authorized VPG personnel to obtain written terms and conditions regarding products designed for such applications.

Product names and markings noted herein may be trademarks of their respective owners.

Copyright Vishay Precision Group, Inc., 2014. All rights reserved.